

PRODUCT DESCRIPTION

Portable 14 Gallon Self-Contained Heated Gravity Fed Eyewash with insulated jacket used in areas where plumbed potable water is not available. The heater is designed to maintain water temperature in the tank near 85°F (29°C) to help prevent cold water shock to the user. Model 01104070 Heated Gravity Fed Eyewash unit requires 240V power is suitable for use in NEMA 4 rated or Class 1, Div. 2 Group B, C, D electrically classified areas and is supplied with a 9 ft. (274 cm) heavy-duty SOW 16/3 cord WITHOUT AN ELECTRICAL PLUG (electrical plug to be supplied & installed by others).

COMPONENT PARTS LIST

(see Figure 2)

- A: Gravity Fed Eyewash with Insulated Jacket
- B: "J" Hook (1)
- C: Heating Unit (packed separately)
- D: Hydrosep® Water Preservative (not shown)

WARNING STATEMENT: The area where the Heated Gravity Fed Eyewash is to be used should be evaluated for electrical classification hazard potential. The plug is purposely not supplied with the unit. The installer must supply the appropriate 3-pronged male plug or other connection as may be required as acceptable to local electrical codes and authorities.



FIGURE 1

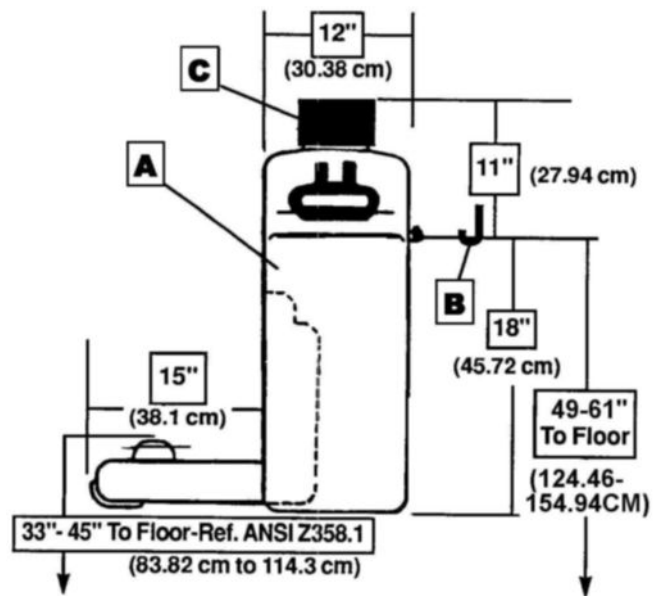

FIGURE 2

GENERAL INFORMATION

Following are requirements of ANSI Z358.1 for Emergency Eyewash and Shower Equipment. A complete copy of this standard may be purchased from International Safety Equipment Association.

1. Eyewash units shall be in accessible locations that require no more than 10 seconds travel time from the farthest hazard.
2. Employees shall be instructed in the location and proper use of emergency eyewash equipment.
3. Each unit location shall be identified with a highly visible sign. The area around the unit shall be well lit.
4. Units shall be inspected annually for proper operation to ensure compliance to ANSI Z358.1 standard.
5. Test records should be maintained verifying compliance with testing procedures.

TRAINING

All employees who might be exposed to hazardous material shall be instructed in the location and proper use of emergency shower and eye/facewash units. Experiences have shown that initial first-aid treatment for irritates should be to wash the eyes and face for 15 minutes prior to medical treatment. It is important to hold the eyelids open and roll the eyes so water will flow on all surfaces and in the folds surrounding the eyes.

INSTALLATION INSTRUCTIONS

CAUTION: Adequate wall support or shelf is recommended. Unit weights in excess of 135 lbs. (61 kg) when filled to capacity.

NOTE: Lag bolt (not included) is required for proper wall installation.

WARNING WARNING WARNING

TO PREVENT A SHOCK HAZARD, USE ONLY WITH A GROUND FAULT CIRCUIT INTERRUPTER.

1. Inspect the inside of the tank. Rinse thoroughly, if necessary.
2. The Gravity Fed Eyewash unit may be mounted on a wall or a shelf. In both cases, the eyewash heads shall be positioned 33" to 45" from the floor.
3. When mounting on a shelf, locate to allow tray to fully open without any obstacles.
4. When wall mounting, install "J" hook to proper support beam 49-61 inches from the floor to the top of the "J" hook, using lag bolt (lag bolt is not included). (See **Figure 2**, page 1, as reference).
5. Tuck the black cap between the jacket and the back of the tank for future use should the heater be removed for servicing.
6. Fill the tank with potable water to the appropriate fill-line and one bottle of Hydrosep® water preservative (supplied). Follow directions on Hydrosep® container.
7. Grip the heating unit assembly at the junction box with the indicator lights facing the front of the tank (see **Figure 3** below). Carefully insert the heating element, float switch and thermostat tee assemblies through the top opening and into the tank. Press down firmly to snap junction box into place.
8. The power cord is now ready for an appropriate 3-pronged electrical male plug (furnished by others), if desired. After installation of electrical plug, insert male plug into a suitable functional 120-volt electrical outlet. Power cord may be wired directly into an appropriate electrical source.
9. After installation of electrical plug, insert male plug into a suitable functional 120-volt electrical outlet.
10. Mount Gravity Fed Eyewash on a shelf or suspend from the "J" hook as described above.
11. Pull down eyewash tray to activate for 15 seconds to test unit for proper water flow pattern. Refill to appropriate fill-line with potable water, if necessary.

OPERATION AND MAINTENANCE

WARNING WARNING WARNING

HEATING ELEMENT MAY BECOME WARM. SAFETY PRECAUTIONS ARE NECESSARY TO AVOID INJURY TO THE BODY.

DO NOT PROCEED UNLESS YOU ARE FAMILIAR WITH THE SAFETY PROCAUTIONS NECESSARY WHEN WORKING WITH LIVE ELECTRICAL CIRCUITS.

CAUTION STATEMENTS

Flashing indicator lights suggest a potential problem, inspect and remove from service if necessary.

The back-up thermostat (1-TAS) should never operate if the control thermostat (2-TAS) remains functional. In the event both thermostats fail, the water can overheat. It is important that the temperature of the water be checked frequently to insure a safe water temperature at/or below 95°F (35°C).

INDICATOR LIGHTS

Green Power ON
Orange Heater ON
Flashing Yellow Low Temp.
Flashing Red High Temp. or
Low Water Level

- 1) The Encon Heated Gravity Fed Eyewash has been tested to -20°F (-29°C). The three conditions listed below must be satisfied before the heating element is energized.
 - a) Float Switch (1-FS): The tank should be filled to the fill-line. Note: If water level falls below the float, the float switch OPENS, de-activating the heater (1-HTR). A flashing red light will indicate this condition. This feature is intended to prevent the heater unit from burning out.
 - b) The control thermostat (2-TAS) senses the water temperature and controls the heater (1-HTR). When water temperature reaches 85° to 90°F (29°C to 32°C), 2-TAS will OPEN and 1-HTR is de-energized. When water temperature falls below 85° (29°C), 2-TAS will reset (CLOSE) to energize the 1-HTR.
 - c) The back-up thermostat (1-TAS) CLOSES when water temperature reaches 95°F (35°C). A flashing red light will indicate this condition. 1-TAS will only CLOSE in the event the control thermostat (2-TAS) fails. 1-TAS will reset (OPEN) when water temperature falls below 95° (35°C).

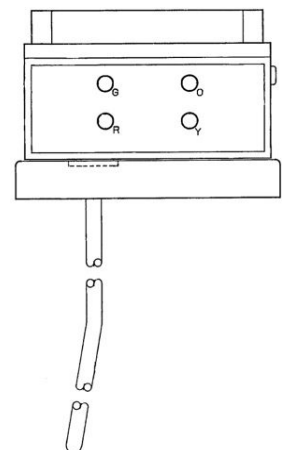

FIGURE 3
Junction Box – Front View

- 2) Clean tank with mild soap and water as needed. Rinse thoroughly and refill with clean potable water to appropriate fill-line and add Hydrosep® water preservative. Hydrosep® water preservative should be added when filling the unit after use, cleaning or testing. Follow directions on Hydrosep® bottle.
- 3) Keep tray closed to protect eyewash heads and shut off water. Do not lean on tray when in open position.
- 4) Activate once per week for 15 sections to flush lines and verify proper operation. Refill to appropriate fill-line after each test with clean potable water. It is not necessary to add Hydrosep® if instruction #3 (above) is followed.
- 5) Unit should be drained, flushed, and refilled with potable water and Hydrosep® water preservative every 90 days (not to exceed 180 days). More often if condition warrants. Follow directions on Hydrosep® container.
- 6) Disconnect power source **before** servicing heating unit.
- 7) The heating unit assembly should be inspected at each cleaning cycle or refill of the tank.
- 8) If the heating unit is removed from the tank for a period of time, the tank opening should be covered to keep the tank free from debris. Locate cap tucked between the insulated jacket and the back of tank. The cap can be used to close the opening.
- 9) Inspect power cord and junction box for visible damage.
- 10) To inspect junction box loosen the four (4) screws and remove junction box lid. There should be no dust or moisture present.
- 11) Check for loose wires, ensure terminal screws are tight and free of corrosion.
- 12) Check relay plate screw is tight and relay is secure.
- 13) Inspect PVC joints of the thermostat and float assemblies for cracks. Dry and reseal with PVC cement or replace, if necessary.

TROUBLESHOOTING

CAUTION: In the following steps, the heater element may become warm and should not be touched or come in contact with combustible materials.

Before proceeding with testing, open junction box lid to ensure all terminal screws are tight and free of corrosion. Test unit for proper operation by:

1. Grip the junction box with hand and carefully lift up vertically to remove heating unit out of the tank. Ensure the float switch (1-FS) is at the lower limit of its stroke. Plug-in power cord of the heating unit assembly into a suitable functional 120V electrical out-let. Is green light lit?
 - a. YES. Go to Step 2.
 - b. If NO, and there is electrical power at the source, have an electrician check unit circuitry in accordance with **Figure 4**. If repairs are necessary and made, repeat Step 1.
2. With the heating unit still plugged in, raise float to the upper limit of its stroke for about 2 to 3 seconds. Is orange light lit?
 - a. YES. This indicates the float switch (1-FS) is CLOSED. Go to Step 5.
 - b. NO. Relay (1-CR) or float switch (1-FS) is not functioning. Control thermostat (2-TAS) is OPEN. Go to Step 3
3. Have an electrician perform an electrical continuity test on the relay (1-CR) using a volt/ohm meter wired to #4 and #3 connections. (NOTE: Temperature must be below 95° to ensure 1-TAS remains OPEN.) Is an electrical continuity indicated on the relay?
 - a. YES. Go to Step 4.
 - b. NO. Replace relay (1-CR). Repeat Step 2.
4. Have an electrician check float switch electrical continuity by disconnecting the float switch wires in the junction box (see **Figure 4**). Attach wire to a volt/ohm meter and check electrical continuity by engaging the switch. Is an electrical continuity indicated on the float switch?
 - a. YES. Go to Step 5.
 - b. NO. Replace float switch (1-FS). Repeat Step 2.
5. Unplug the power cord and immerse the thermostat/float switch tee assembly in cold water (less than 60°F / 16°C) for approximately 5 minutes. This should be sufficient time to reset (CLOSE) the control thermostat (2-TAS) and low temperature thermostat (3-TAS). Go to Step 6.
6. Remove assembly from cold water and plug-in the power cord into a suitable functional 120V electrical outlet. Is the orange light lit (indicating the heater [1-HTR] is energized)? Is the yellow light flashing (indicating the low temperature thermostat [3-TAS] is CLOSED)?
 - a. YES. Go to Step 7.
 - b. NO. Contact Encon Customer Service at 1-800-283-6266 for discussion and instructions on returning heating unit assembly for evaluation.

**FIGURE 4
ELECTRICAL SCHEMATIC**

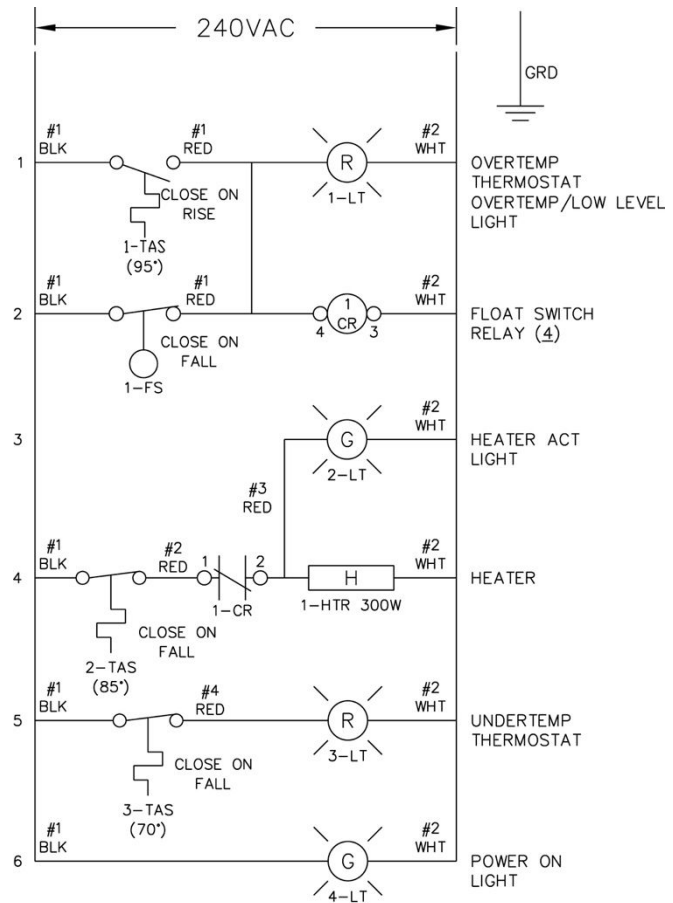

WIRING LADDER DIAGRAM

7. With the heating unit still plugged in, return heating unit assembly to cold water (less than 60°F / 16°C) and monitor water temperature until orange light turns off. Flashing yellow light will turn off when the water temperature reaches 70°F (21°C).
 - a. If water temperature is between 85° and 95°F (29° and 35°C) and orange and yellow lights are off, replace heating unit assembly in tank and place eyewash unit back in service.
 - b. If water temperature does not reach 85°F (29°C) or exceeds 95°F (35°C), which is indicated by flashing red light, contact Encon Customer Service at 1-800-283-6266 for discussion and instructions on returning heating unit assembly for evaluation.

REPLACEMENT PARTS LIST

P/N 01104049M	Heater & Insulated Jacket Assembly	P/N 01110721	Female Latch
P/N 01110790M	Insulated Jacket	P/N 01110792	Discharge Hose
P/N 00014670	Float Switch (1-FS)	P/N 01110738	J-Hook
P/N 01110397	Control Thermostat (2-TAS)	P/N 01110764	Hydrosep® Water Preservative (4 - 8oz. bottles per carton)
P/N 00014745	Relay (1-CR)		
P/N 01110720	Male Latch		

PROPOSITION 65

WARNING: This product can expose you to BPA, which is known to the State of California to cause birth defects or other reproductive harm. For more information go to www.P65Warnings.ca.gov.

WARRANTY STATEMENT

ENCON HEREBY DISCLAIMS ALL WARRANTIES EXPRESSED OR IMPLIED INCLUDING BUT NOT LIMITED TO WARRANTIES OF MERCHANTABILITY, FITNESS FOR A PARTICULAR PURPOSE, AND NON-INFRINGEMENT OF THIRD-PARTY RIGHTS, EXCEPT AS HEREINAFTER PROVIDED.

Encon Safety Products warrants that for one year from the date of purchase of any Encon products, the product will be free of defects in materials and workmanship if properly used and cared for or cleaned under normal conditions in accordance with Encon’s use and care instructions and properly installed, if applicable, in accordance with Encon’s installation instructions. With respect to the product, Encon’s only obligation and purchaser’s exclusive remedy under this warranty is to repair or replace such product; provided that:

1. Encon is notified of the defect within one year of shipment, and
2. the product is determined by Encon to be defective.

Encon requires proof of original ownership as proof of warranty coverage, and Encon must receive any claim under this Limited Warranty within one year of purchase of the product.

NOTWITHSTANDING ANYTHING TO THE CONTRARY CONTAINED HEREIN, ENCON SHALL NOT BE LIABLE FOR LOSS, DAMAGE, OR EXPENSE ARISING DIRECTLY OR INDIRECTLY AS A CONSEQUENCE OF USE OF THE EQUIPMENT WITH OTHER PRODUCTS OR FROM ANY OTHER CAUSE, INCLUDING ANY CONSEQUENTIAL, INCIDENTAL, SPECIAL OR EXEMPLARY DAMAGES, EXCEPT FOR ENCON’S OBLIGATION TO REPAIR OR REPLACE DEFECTIVE PRODUCTS AS EXPRESSLY PROVIDED IN THIS STATEMENT.

Replacement parts purchased from Encon are warranted for one year following the shipment of such replacement part, or until the expiration of the warranty period for the product, whichever is less. No warranty is given in connection with products that are altered without Encon’s expressed written consent. The same warranty limitations and the obligations of Encon as set out herein above shall apply to replacement parts.

Encon’s total liability arising out of this warranty (including, but not limited to, warranty claims) regardless of forum and regardless of whether such action or claim is based on tort, contract or otherwise will not exceed the total purchase price of the product.



6825 W. Sam Houston Pkwy. N
Houston, TX 77041
1-800-AT-ENCON / 1-800-283-6266
customerservice@enconsafety.com
<http://www.enconsafety.com>